

The MPFMP-060 volumetric pocket filler dispenses clean, accurate portions of a wide variety of difficult to fill products including:

- Cooked rice
- Cooked pasta (long & short goods)
- Cut vegetables & fruit
- Ready-to-eat salads
- Cereal
- Surimi, shrimp, & shredded meats



This filler is ideally suited for lower speed production lines, research and development labs, and pilot plant operations. It is rated at speeds up to 50-60 cpm, depending upon the product, volume to fill, container, line configuration, and operator. Product is loaded into the top pan



and manually fed to the filling tube by an operator.

The head is designed with an adjustable volumetric pocket system equipped with either a plate product separation device, sharp knife, or needle assembly depending upon the type of product being filled. The discharge is controlled in synchronization with the container flow.

The filling head can be quickly and completely disassembled without tools.



MPFMP-060 front view
*Shown with optional spare parts rack



A small Allen Bradley PanelView graphics terminal provides a user friendly interface to the PLC for set-ups with production, test, and clean modes. With less moving parts, adjustments can be done while the machine is operating and maintenance is reduced.

Level control is accomplished by keeping the filling tube full.

A no-container, no-fill function is activated by a proximity sensor located near the filling head.

The compartmentalized stainless steel enclosure (manufactured to NEMA 4X, IP66 standards) contains all of the pneumatic and electrical components.

A Venturi vacuum system assists the product flow. It is a stainless steel maintenance-free variable pneumatic line vacuum system. There are quick coupling fittings for pneumatic connections.

This mobile unit can be quickly cleaned and moved to a different production line in minutes, ready to fill a different container with few or no change parts.

The MPFMP-060 can be fitted with smaller/bigger filling change parts as well as a two-position distribution system.

All systems are manufactured to the standards of major regulatory bodies such as ANSI, FDA, USDA, and CE.



STANDARD VOLUME CHART			
Filling Head Assembly	Standard Range	Optional Range	Special Range
2.00" (51 mm)	47 to 165 cc	145 to 188 cc	
2.75" (70 mm)	93 to 339 cc	317 to 457 cc	447 to 636 cc
3.25" (82 mm)	123 to 459 cc	429 to 619 cc	
4.75" (121 mm)	267 to 887 cc	744 to 1,211 cc	up to 1,700 cc



MPFMP-060 rear view
*Shown with optional spare parts rack

MPFMP SPECIFICATIONS

- AIR CONSUMPTION = (⊙ 60 CPM) 80 PSI ⊙ 30-35 CUBIC FT./MIN
5.5 BARS ⊙ 51-60 NM/HOUR
- POWER REQUIREMENTS = (1) PHASE 120/230
TOTAL POWER REQUIRED WITH AIR VACUUM PUMP= 60W
- APPROXIMATE HOPPER CAPACITY FULL = 35.0 GAL. 132.0 LITERS

NOTES:

- STANDARD HEAD SHOWN 4.75 & 5.75 APPROXIMATELY 3.00 LESS
- SPECIFICATIONS SUBJECT TO CHANGE WITHOUT NOTICE.
- ALL DIMENSIONS +/- 1.0 [25]

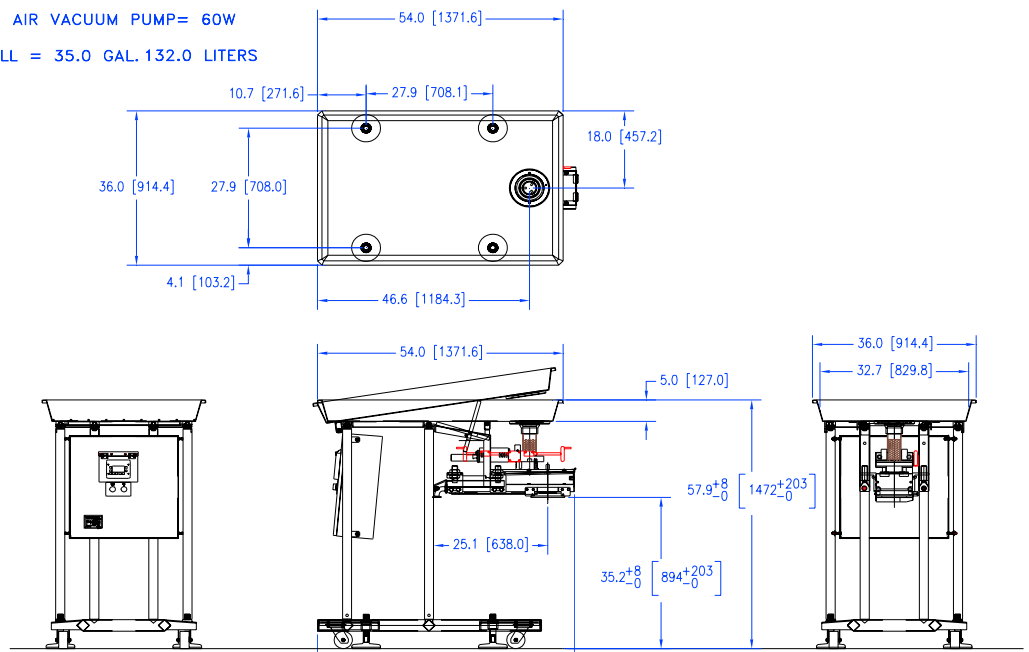

NOTE: DIMENSIONS ARE IN INCHES [mm]